

energizing lives

corporate profile



ABOUT US

National Gas Company, a fully Omani owned Joint Stock Company is the pioneer in LP Gas Marketing in the Sultanate of Oman. The company was incorporated in 1979 to meet the growing LPG requirements of consumers in the region. In 1981, the company started bottling operations, heralded the beginning of LPG industry in Oman and has today spread its wings over the entire country by having 6 strategically located plants. We energize lives by offering solutions that celebrate dreams and the can-do spirit of our consumers.

The Company has sustained its pioneering status as energy solutions provider in the Asian Energy Market by maintaining continuous growth and innovation. With presence in Oman, United Arab Emirates, Saudi Arabia, Qatar and Malaysia, the company is now focusing on emerging markets in the energy sector.

The company diversified to associated valued added businesses to increase its presence, customer satisfaction and shareholder's value.



الغاز الوطنية
National Gas



OUR HISTORY

National Gas Company was set up with a vision to meet LP Gas consumption need in the region. During the late 1970's, the need to set up a local bottling plant was prompted by the problems faced by the local gas dealers, who had to travel to Dubai and Abu Dhabi to collect cylinders. Moreover there were frequent shortages due to Omani dealers being given last priority. Our first Chairman, Mr. Mohd Abdul Rasool Al Jamali, a true visionary, was instrumental in setting up the National Gas Company.

- 1981:** NGC started its operations;
- 1987 - 2003:** NGC set up seven LPG bottling plants at strategic locations
- 2005:** NGC started Aerosol Propellant Gas production and sale to customers
- 2006:** NGC started its export LP Gas Business to UAE
- 2008:** NGC pioneered the first SNG system in Oman
- 2008:** NGC started Cutting Gas business in Oman
- 2009:** NGC formed its 100% subsidiary arm "NGC Energy FZE" in the UAE
- 2009:** NGC set up the first integrated township gas system in Sohar, Oman
- 2010:** NGC started Cutting Gas business internationally in the UAE & other countries thereafter
- 2010:** NGC commenced D Cylinder business in Oman
- 2011:** NGC set up the largest SNG system for a major international steel plant in Saudi Arabia
- 2012:** NGC acquired Shell's LPG Business in West Malaysia
- 2014:** NGC Explored Enhanced Oil Recovery segment with the help of LPG
- 2015:** NGC started its fully owned entity in Saudi for addressing LPG market demands
- 2016:** NGC launched lubricants division
- 2018:** NGC inaugurated to set up 30 K MT LPG Import and storage terminal in JV with Petredec, in India (Krishnapatnam port)

THE NATIONAL GAS BRAND

With an aim to achieve a clear, consistent visual identity that reflects the company's mission and core values, National Gas launched a new logo during its 25th anniversary celebrations in 2006. The dark blue flame in the logo represents pure energy and continuous innovation, while the light blue flame signifies a caring hand, with a focus on company's CSR initiatives.

350,000 MT ANNUALLY

National Gas handles more than 350,000 MT Annually from 10 plants in Oman, Malaysia & UAE

1

LARGEST FLEET

National Gas operates largest Fleet of LPG Tankers & Bobtails in Oman

2

LARGEST LPG STORAGE

Largest LPG Storage in Oman with 2600 MT Capacity

3

HIGHLIGHTS

ISO & QHSE

Highest HSE Standards & ISO Certified LPG company in Oman

4

5

AUTHORIZED FOR TANK CERTIFICATION

From Civil Defense Oman

6

PIONEERING OMANI LPG COMPANY

With a track record of highest safety standards & well trained man-power

OUR VISION

National Gas Company envisions being the number one non-government Energy Company in its areas of operation, through innovative solutions, exceeding stakeholder expectations.

OUR MISSION

We will accomplish our vision by:

- Pursuing innovation as a path to deliver superior energy products to our consumers and thereby attaining customer delight
- Ensuring the satisfaction of our shareholders, partners and employees by supporting them to achieve and exceed their goals
- Continuously striving to enhance our performance by adopting high quality control, implementation, optimization and advanced safety practices
- Maintaining the highest level of integrity in all our dealings, and contributing responsibly towards environment, community and the nation



OUR OPERATIONS

The company was incorporated in 1979 to meet the growing LPG requirements of consumers in the region. In 1981, the company started best in class bottling operations, heralded the beginning of LPG industry in Oman and has today spread its wings over the entire country by having 6 strategically located plants.

The company operates a large fleet of tankers to lift bulk LPG from refineries in the Sultanate to its plants where it is bottled into cylinders in safe and controlled conditions. Company has different sizes of tankers to meet customer demand and reduce distribution cost. All the vehicles are equipped with high standards of safety, online monitoring and tracking devices. The company imparts training to its drivers on a regular basis for safe transportation of product.

We follow IMS systems and comply with ISO: 9001; 14001 & 18001 to maintain highest safety standards, quality and customer satisfaction. All of our plants are equipped with state of the art technology and operate with highly skilled manpower. The company has in house production of aerosol propellant gas and cutting gas

The company's project & engineering division takes care of design, engineering, procurement, installation, commissioning and testing of all projects and post sales services.



OUR STRENGTHS

National Gas is the first LPG marketing company in the Sultanate of Oman with over 40 years of experience in the region as well.

National Gas is certified ISO 9001 for quality management, ISO 14001 for environment management and OSHAS 18001 for safety management.

Approved Oman Government Third Party Inspector for inspection and issuing Third Party Inspection Certificate for all Pressure Vessels.

Designed, installed and commissioned the very first Synthetic Natural Gas system in Sultanate of Oman & in the GCC region.

Installation of telescopic conveyor system in Rusayl plant and Installation of online semi-automatic filling machine.

The company has a proven track record of serving domestic, commercial and industrial consumers efficiently, reliably and safely.

Well-established HSE systems and practices ensure consumer safety at all times

The company is the one-stop-shop for design, engineering, installation, operation and maintenance of Bulk Gas installations and supply of Bulk LPG



NGC PRODUCT OFFERINGS:

LPG CYLINDERS

National Gas offers LPG in cylinders that virtually cover almost every area of North Oman. Cylinders are available mainly in 22 Kg and 44 Kg sizes and to a lesser extent in 11 Kg and as barbeque cylinders. LPG cylinders are used by domestic, commercial and small industrial consumers.



AEROSOL PROPELLANT GAS

National Gas Aerosol Propellant is a proven environment friendly alternative to Chlorofluorocarbons (CFCs) which are detrimental to the earth's protective ozone layer and are due to be phased out as per several International agreements. Aerosol Propellant is used by manufacturers of Pesticides, Air-fresheners, Perfumes, Cosmetics, Spray Paint and Food grade packaging material



D-CYLINDER

It isn't just a revolutionary LPG cylinder. It's a Savings Bank.

The D-Cylinder is the most advanced LPG cylinder designed as per DOT-4BW-250, introduced for the first time in Oman by National Gas Co. SAOG. Its' state-of-the-art features are designed to enhance safety, convenience and save costs, making it the perfect solution for hotels, restaurants and bakeries

SYNTHETIC NATURAL GAS

Synthetic Natural Gas (SNG) is a potential solution in many parts of the world where Natural Gas availability and reliability problems create industrial havoc. Synthetic Natural Gas is a blend of LPG and Air to provide direct replacement for Natural Gas. This technology plays a critical role in meeting the interchangeable energy (fuel) requirement of the industries.



BULK LPG

Bulk LPG supply has inherent advantages to industrial users giving them the flexibility and control for using it for multiple applications in an extremely safe manner. Bulk LPG is used extensively by medium scale industries like ceramic, glass, metal works, food and dairy and by commercial establishments such as hotels and resorts.

PROPANE

We are the reliable source for commercial/industrial grade propane used for heat treatment, stress relief operations & other industrial applications

THE INCREDIBLE CUTTING GAS

National Gas has developed a revolutionary new alternative cutting technology that will change the way metal is cut. The Cutting Gas is a hydrocarbon-based cutting solution that offers unmatched economy on overall cutting, higher safety, operation friendly usage and less carbon emission as compared to conventionally used Acetylene.

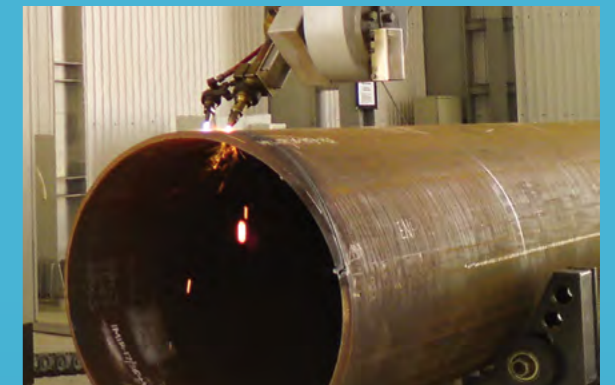

INTERNATIONAL SERVICES



Consultancy and Engineering support for LPG Market Assessment, Developing LPG Market Strategy, Design, Engineering & Installation of LPG terminals, Bottling Plants & Bulk Gas System, Integration with Natural Gas System and Fire Safety System Design.

Operations facilities include Developing Operational Manuals, LPG Plant Maintenance, Operation and Safety Training, Logistic Planning/Fleet Optimization and Operations & Maintenance of Bulk Systems.

Marketing Services cover New Market Development, Township Gas System, Synthetic Natural Gas, LPG System for Enhanced oil recovery Projects. Aerosol Propellant, Cutting Gas and Conversion from alternate fuels to LPG. Equipment Supply – National Gas can supply reliable, efficient and state-of-the art LPG and Natural Gas equipment with a wide range, which include LPG Tanks, LPG Vaporizers, LPG Pump, LPG Compressors, Plant Equipment and all related accessories.

D – CYLINDER

What is D – Cylinder

This is the most advanced LPG cylinder introduced in Oman since 2010. It's state-of-the-art features are designed to improve safety, convenience and save costs. It is the perfect solution for restaurants, hotels, bakeries, camps & catering companies.

- Enhanced safety because of safety relief valve provided on D-Cylinder
- Level indicator (Rochester gauge) for checking LPG quantity in D-Cylinder
- 100% utilization of LPG in the cylinder
- No change of D-Cylinder Required, once installed our vehicle will come and fill it

The most advanced LPG Cylinder

The D-cylinder equipped with features like Rochester level gauge, onsite filling, pressure gauge, excess flow check valves and safety relief valves. The D-cylinder aims to address concerns encountered by commercial establishments such as insufficient gas withdrawal from conventional cylinders due to which customers tend to face frequent burner problems. Its' gas level monitor device ensures that you pay for what you use without wastage. This guarantees 100% utilization since there is no leftover gas.

Features for 100% customer satisfaction

National Gas is the pioneering company that introduced the D Cylinder concept in Oman. National Gas has the

largest fleet of bobtails, apart from strategically located Bulk storage spread over the Sultanate for reliable supply to D Cylinder customers that rely on uninterrupted energy availability for their business activities.

National Gas follows strict internal procedures and scheduling systems that not only assure consistently high quality of LP Gas supply to its customers, but also ensure that clients never run out of gas.

Consumption

Unlike regular LPG cylinders, where you will pay price of full cylinder but you will only use around 80% of the LPG inside regular cylinder, D-Cylinder makes it possible to consume 100% LPG.

Satisfaction

D-Cylinder provides peace of mind. In comparison to regular LPG cylinder, D-Cylinder installation and supply removes practices such as daily basis cylinder changing, pouring hot water to get more pressure and LPG, manually checking regularly to note the quantity of LPG present in Cylinder. D-Cylinder eliminates all of these problems.

Ease of Handling

With D-Cylinder you will get on-site filling, efficient usage of space, and ease to monitor and control LPG levels/stocks.

It is not only safe, easier to use, efficient, gives you peace of mind-but it also gives you upto 20% cost savings.



DELIVERY NETWORK

Largest LPG Delivery Network in Oman

COVERING MUSCAT - SOHAR NIZWA - SALALAH

National Gas Company is Oman's largest and most progressive LPG marketing company having 6 plants in different strategic locations in Oman. We operate Oman's largest fleet Bobtails & Tankers for delivering LPG. We are covering D-Cylinder customers in Muscat, Sohar, Nizwa, Salalah We are adding more areas our delivery network

1D-Cylinder: 350 Liters LPG (water capacity 440 Liters)

1 Regular 44kg LPG cylinder: 78 liters minus

(15 20%) LPG left in regular cylinder

1D-Cylinder = Aproximately 5 No.s 44kg cylinders

Steps for converting to D-Cylinder:

1. NGC Sales Visit, NGC HSE Visit
2. Civil Defence visit for certification
3. Agreement Signing, Gas Bank preparation
4. First Fill Inspection, Regular Supply



BULK GAS INSTALLATIONS / NETWORK

National Gas undertakes turnkey jobs for design, installation, commissioning, operation and maintenance of Bulk LPG tank installations with related piping and distribution systems. National Gas is equipped to integrate small to large industrial installations and township piped gas distribution networks based on National Gas' unique-ownership options to the customers.



GAS ENGINEERING AND PLANT INSTALLATION

National Gas undertakes turnkey jobs for design, engineering and commissioning of LPG Bottling Plants, Deodorized Unit and Aerosol Filling System, Auto Gas Refueling Station, Pressure Reducing Stations and Gas Metering Stations, Synthetic Natural Gas Systems, Gas Powered Power System and Gas Refrigeration/Air-conditioning Systems.



NGC EORS

Enhanced Oil Recovery Project: Steam Injection

In this approach, various methods are used to heat the crude oil in the formation

- To reduce its viscosity and/or vaporize part of the oil and thus decrease the mobility ratio.
- The increased heat reduces the surface tension and increases the permeability of the oil.
- The heated oil may also vaporize and then condense forming improved oil.

Methods include

- Cyclic Steam Injection.
- Steam Flooding.

Steam Flooding

- Heat is introduced to the reservoir by pumping ,steam is pumped into the well with a pattern similar to that of water injection.
- Eventually the steam condenses to hot water; in the steam zone the oil evaporates, and in the hot water zone the oil expands.
- Oil expands, the viscosity drops, and the permeability increases.. This is the principal enhanced oil recovery program in use today.

Client Information

- Fuel requirement for OTSG-on the basis of Flow rate, and input pressure
- Understanding the process: Batch /Continuous process
- Back Up Requirement/Buffer Stock required by the customer

EOR Projects-Equipment Selection

- Vaporiser is selected on the basis of customers requirement: Mobile/Fixed Vaporiser
- Selection of tanks : Movable(Wheel Mounded)/Immovable Tanks as per site demand
- Burner Selection on basis of flow rate
- ROI of 3 to 6 months with savings upto 40%

Sr No	Client	Type of Project	Capacity	Storage Capacity in MT	Year
1	PETROGAS	EOR-STEAM INJECTION	42MMBTU/hr	52 MT	2017-2018
2	MEDCO	EOR-STEAM INJECTION	40MMBTU/hr	50 MT	2015
3	STEAM TECH	EOR-STEAM INJECTION	42MMBTU/hr	44 MT	2019



NATURAL GAS SOLUTIONS

National Gas undertakes to provide solutions for PRMS Installation, Pressure Testing, Meter Changing, LUAG (Work Loss unaccounted gas) to PEIE in industrial estates tapping from main Natural Gas header, Manhole modification, NG Piping and Work Loss

We have done numerous projects for our customers located inside various PEIE's in Oman. Some of our major customers are as follows:

PEIE – Sohar: Al Maha Ceramics

PEIE Rusayl: Oasis, Oriental Polystyrene

PEIE Salalah: Oman Food Stuff & Global Gypsum

However Al Hael Ceramics under PEIE Sur is one of the biggest NG project.

PEIE Sur:

- Al Hael Ceramics
 1. Biggest NG Station
 2. Set up 7000 Cu. Mtr/hr NG PRMS Station
 3. 10" ,700 Metre long pipeline, 315 OD



NC+ THE INCREDIBLE METAL CUTTING GAS FROM NATIONAL GAS COMPANY

NC+ is a unique hydrocarbon industrial gas mixed with an innovative additive that enhances flame temperature and produces fine cut finish at very low cost compared to DA.

SAFER, STABLE, NON REACTIVE, LESS PRICE, LESS FLASHBACK, BETTER CUTFINISH



Innovation

NC+ is one of the cleanest burning, easiest to use, best performing and safest fuels available. With most products you have to pay extra to get the best, but with NC+ you get this high level of quality and still save money. It is stable in both liquid and gas states, economical, produces little slag, and has a very high heat value.



High heat value

It has a very high heat value. This heat value is due to the fact that the molecules in NC+ are united in a bigger bond than acetylene..



Safer

NC+ does not have the withdrawal pressure limitations that are necessary with acetylene. It is very stable unlike acetylene and has will produce less flashback and cannot auto ignite.



NC+ VS Acetylene A Fair Comparison

Safety data comparison

Safety Data	DA	NC+
Shock sensitivity	Unstable	Stable
Backfire tendency	Very high	Low
Explosive limit in air	3 – 93 %	2.5 – 9.3 %
Burning velocity	22.7	15
Auto ignite	Yes	No
Flashback Potential	Dangerous	Minimal
Operating Pressure	1-15 psi	1-133 psi
Gas stability	Unstable	Stable
	Dissolved in acetone with filler	No filler or solvent

Upto 60% Reduction in inventory

As one cylinder of NC+ equals to 7 cylinders of DA, the stock is also decreased by upto 60%. That results in more storage area to be used.

Upto 60% Reduction in handling time

DA requires frequent change over time for cylinders to be replaced. This change over time is reduced by 60% and as a result, man hours can be saved.

Safer

NC+ is a stable gas as compared to Acetylene and hence safer

- Stable as compared to Acetylene
- No withdrawal issues
- 10 times lower flammability limit
- Cannot autoignite
- Minimal flashback

Cost Effective

NC+ gives overall 40% cost saving as compared to DA

- NC+ 22KG Gas in 44KG cylinder as compared to DA 3.5 KG in 70KG cylinder
- Reduction in inventory
- Reduction in man hours dedicated to changing cylinder
- Life of tools increases because of less carbon deposit

Increased Efficiency

NC+ is a versatile gas that can be used in multiple operations with excellent results

- Higher total heat value
- Less slag formation
- Narrow kerf and hence better cut finish
- High penetration and faster cutting speeds
- Less carbon deposit
- More efficient for heating & versatile operations can be done

Applications Covered

- Hand Cutting,CNC operations,Pug Machines,Brazing,Soldering,Preheating Heat treatment,Billet Cutting up to 300 mm plates

WHAT IS SNG?

Synthetic Natural Gas (SNG), is a blend of LPG and diluents such as Compressed Air, Biogas, Digester Gas, Landfill Gas, or Nitrogen. SNG is a direct replacement for Natural Gas, and plays a critical role in meeting the interchangeable energy requirements of the Industry.

The ratio of LPG to diluent depends on Wobbe Index of the fuel (Natural Gas) to be replaced. Similar Wobbe Index ensures that the two different fuels behave exactly the same and fuel swapping becomes seamless.

Two different gases with an identical Wobbe Index will produce an equal amount of heat with the same amount of combustion air from the same burner. Matching the Wobbe Index of two fuels ensures that the changeover will be seamless with no change required in either pipelines or combustion equipment

Wobbe Index is calculated by dividing CV with under root of specific gravity:

$$I_w = \frac{V_c}{\sqrt{G_s}}$$

V_c is the higher heating value, or calorific value

G_s is the specific gravity

I_w is the Wobbe Index

Natural Gas

V_c : 1017 BTU/SCF

G_s : 0.60

$$I_w = \frac{1071}{\sqrt{0.60}} = 1312$$

SNG

V_c : 1502 BTU/SCF

G_s : 1.31

$$I_w = \frac{1502}{\sqrt{1.31}} = 1312$$

WHY USE SNG?

Natural Gas is a vital component of the world's supply of energy. It is one of the cleanest, safest, and cheapest energy sources widely used in residential, commercial, and industrial applications. Over a period, the increased usage of Natural Gas leads to a mismatch in the demand and supply ratio creating a scarcity of Natural Gas.

SNG is a viable alternative when there is an absence or a shortage of Natural Gas. SNG can be used to precede the availability of Natural Gas or to augment the Gas supply where Natural Gas is already available.

The SNG system can be virtually designed to meet any energy demand due to its modular nature. It can also be designed to give tailor-made solutions to suit specific process requirements in different working scenario.

1) SNG as base Load system:

Provide SNG in region where NG is currently not available. SNG base load system provides continuous and uninterrupted fuel supply to meet full load energy demand.

2) SNG as Standby System:

SNG will provide an ideal standby fuel in the event Natural Gas source is unavailable due to curtailment, maintenance shutdown or catastrophic failure or interruption of Natural Gas supply.

3) SNG as Peak Shaving System:

SNG Peak Shaving System acts as asset as well as profit protection tool in case of shortage or inadequate supply of Natural Gas. It will also help to mitigate price volatility during peak demand period.

SNG systems provide a convenient, consistent, high quality fuel with combustion characteristics similar to Natural Gas. In emerging economies where Natural Gas is in its infancy, SNG plants allow local Gas utility firms to "build up" a customer base during planning and construction of a Natural Gas transmission system. The availability of SNG also supports commercial and industrial growth since such customers can install Natural Gas equipment and commence their production without waiting for arrival of the Natural Gas. This way Industries save substantial interest costs by commencing production on time.

The advantages of SNG under specific situations are obvious. One of the benefits of using SNG is that it eliminates re-condensation problems commonly associated with undiluted LPG vapor, as the "tempering" of the LPG with air suppresses the dew point.

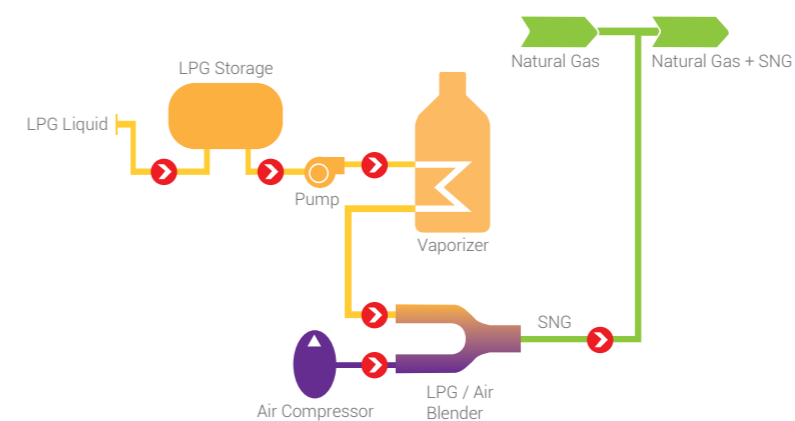

SNG FUNCTION BLOCK DIAGRAM

WHO CAN BENEFIT FROM SNG?

SNG can be an ideal solution under following situations:

- Inadequate Natural Gas supply
- No Natural Gas supply
- Natural Gas is not available in the region currently but system needs to be designed for Natural Gas to avail future benefits
- Natural Gas pricing opportunities

Unique features of SNG system make it an ideal solution for:

- Large and Medium scale industries
- Avoiding investment in dual fuel Burners
- Optimization of Production Capacity
- Critical Industrial applications like Float Glass, Fiber Glass, Food, and Ceramic (Where Lance Burners are used)
- Low switchover cost and risk
- Save in Insurance Premium by using SNG as back up
- Utility Companies
- Being able to meet peak grid demand by injecting SNG
- Hotels / Commercial Complexes
- District Cooling / Heating Units

WHY NATIONAL GAS FOR SNG?

Trusted Name

National Gas Company (SAOG), a public listed company based in the Sultanate of Oman, with group business turnover of 250 million dollars. Over the period of time National Gas Company has transformed itself from a local Omani company to a Multinational organization with well-diversified product portfolio and wide spread international presence across middle east and asia. National Gas enjoys pioneering status as energy solutions provider in the region with innovations and high standards of customer service. National Gas Company has successfully designed, installed and commissioned SNG systems across the GCC in different industries for varied applications.

Industry Specific Solution

We provide industry specific tailor-made solutions to suit process requirements like LPG-NG mixing technology to meet additional or constant heat of mixed Gas by eliminating air as diluent. Similarly LPG – Bio Gas SNG can be utilized to maximize use of Bio Gas.

National Gas has designed systems ranging from 20 MMBTU/ Hr up to 2000 MMBTU/ Hr for various industries like Steel Rolling Mill, DRI, Pelletizing Plants, Ceramic Plants, Construction Material, Aluminum Processing, Float Glass, Fiber Glass, Hotels etc.

We are pleased to say that the systems designed, supplied and installed by National Gas are running smoothly without any interruption even in extreme climatic condition. Just to name a few major SNG Projects designed, supplied, installed and commissioned by National Gas.

Sr No	System Size	Type of Industry	Location	Type of Use
1	1 X 50 MMBTU/HR	Construction Material	Oman	Base Load
2	2 x 60 MMBTU/HR	Steel Rolling Mill	Oman	Peak Shaving
3	2X 348 MMBTU/ HR	Pelletizing Plant	Oman	Base Load
4	1X 348 MMBTU/ HR	Tubular Products	Saudi Arabia	Standby
5	1X 15 MMBTU/ HR	Hotel	UAE	Base Load
6	1X 33 MMBTU/HR	Usg Boral	Oman	Base Load
7	230 MMBTU/HR	Al Hael Ceramics	Oman	Peak Sharing

Customer Service

The ability to extend 24X7 services is the most important aspect in SNG projects as the entire plant's operation is dependent on the reliability of the SNG system. Our core strength is a highly skilled and experienced service team who have specialized knowledge of installation, commissioning, testing and trouble shooting of SNG systems.

One Stop Solution

National Gas offers a reliable energy solution for users coupled with assured local capabilities and proven global expertise. With our experience and trained personnel, we would like to assure the customer an effective, efficient and reliable service all the time.

- One stop shop for Design, Supply, Installation, commissioning of SNG system LP Gas storage facility and Bulk LP Gas supply
- Partnered with a world leading SNG (Synthetic Natural Gas) equipment supplier

GAS GENERATOR

The Nitrogen & Oxygen Generation process is an extremely clean operation and the only 'raw material' is Air. On-site generators allow for an uninterrupted supply of gas with a high purity output. This means that you can produce gas where and when you need it, and in the exact quantity and quality you need.

National Gas services for nitrogen or oxygen generation, designed according to customer's specifications and suitable even for higher capacity as well as extreme ambient conditions. The superior technology of our gas generators represents environment friendly, less maintenance, economic, flexible and reliable.

BENEFITS

- Much more economical compared to Liquid Nitrogen/ High pressure cylinder
- Self-dependence for nitrogen which is one of the key elements of your production
- Better control on purity of the gas which results in end used product quality commitment
- Save time of Purchase/ Finance and operation on ordering liquid nitrogen / high pressure cylinder
- Avoid high risk for storing high pressure and high temperature gas at plant premises

PRODUCT RANGES

1. PRESSURE SWING ADSORPTION (PSA)

- Production of Nitrogen or Oxygen from Compressed Air
- Applied for On Site Production of Nitrogen & Oxygen
- High Efficiency at High Product Purities

2. HOLLOW FIBRE MEMBRANES

- Production of Nitrogen from Compressed Air
- Applied for On Site Production of Nitrogen
- High Efficiency at Lower Product Purities

PRODUCT RANGES

- Safety: Low Operating Pressures, no Hazardous Storage
- Economy: No Distribution, Handling Cost & Low Operating Costs
- Premium Quality & High System Reliability: First Class Materials & Components
- Convenience: Automatic and Unattended Operation
- Guaranteed Nitrogen Quality: No Risk for Insufficient Nitrogen Purity
- Compact: Easy to Transport and to Install
- Unique Flexibility: Unmatched System Lay-Out Flexibility
- Modularity: System upgrade in the future by just adding banks on the existing one

BASIC SYSTEM LAYOUTS

Pressure Swing Adsorption (PSA)

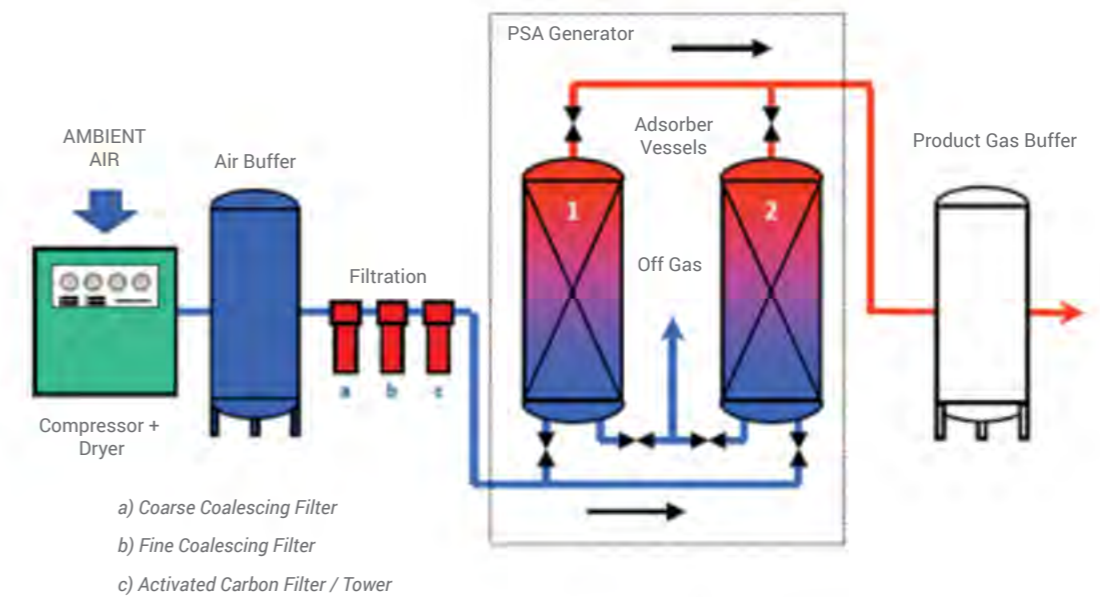

Hollow - Fibre Membranes

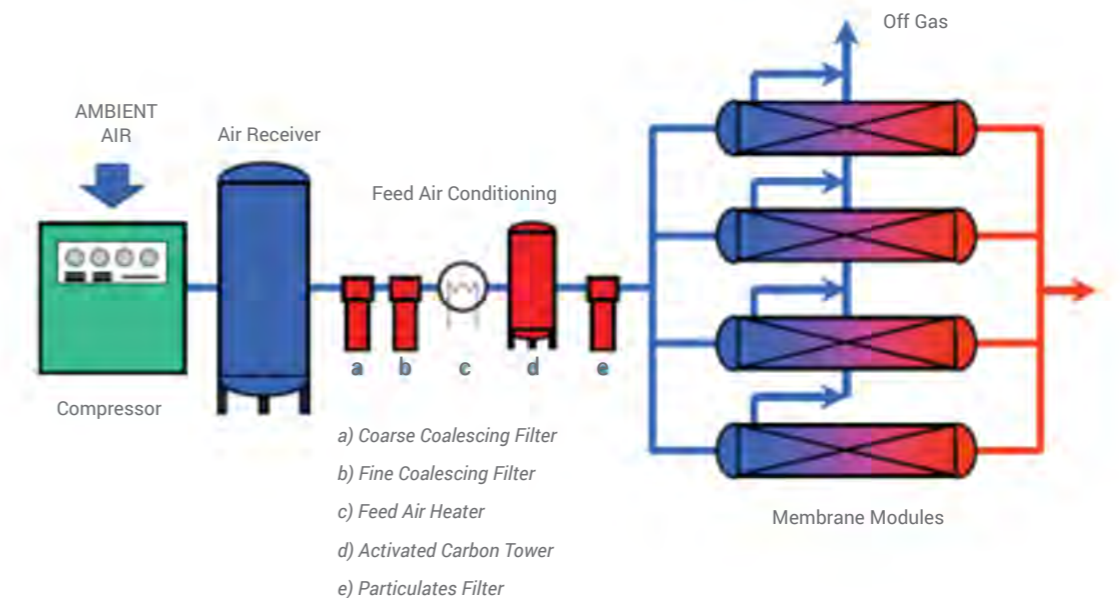



FLARE GAS RECOVERY OPTIONS

CONCEPT

- Stranded gas fields comprise of all the components of a productive field, except that its useful life could be 5 years or less.
- With many such stranded gas fields tied up together into 1 common gas pipe, the total volume of gas available becomes large.
- Recovery of C3/C4 (to make LPG) and cleaning up the other unwanted gases (Nitrogen, CO₂, H₂S and H₂O) through gas treatment technologies and releasing the available “clean” gases through is one way of making economic use of the otherwise “flared” gases.

Benefits:

- Gas pre-treatment plants are available commercially and are mature in design.
- The products recovered and the value earned in total would make this proposition very viable.
- More revenue can be generated from the LNG sales rather than sent to flare
- CO₂ can also be recovered and turned into LCO₂ to make dry ice (for food, dry ice cleaning etc), and gaseous CO₂ for welding and inerting needs.

PRE-TREATMENT SCHEMATICS

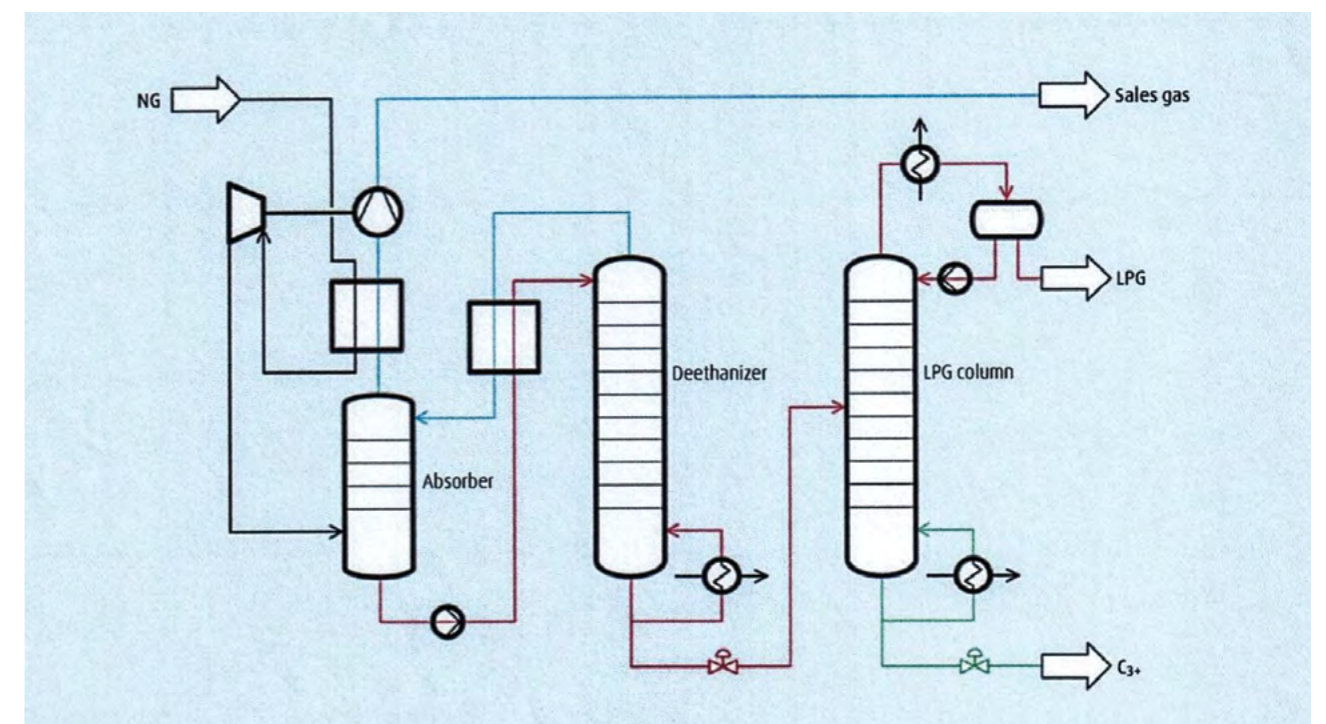



LUBRICANTS

National Gas Company offers IPOL Lubricants with "Cutting Edge Technology & Superior Results".

IPOL is a lubricant brand of GP Global group. Its a 5 BN USD energy company based in UAE providing integrated commodity and services, is a product manufacturer and global recognised brand.

It offers a wide range of products in the automotive and industrial segment along with specialties like coolant, brake fluid, greases etc..

All IPOL products are tested for quality control and their manufacturing locations boast of a fully equipped technology lab where equipments are calibrated and supported as per ASTM.



Automotive & Industrial Range of products

- Automotive Lubricants
- Automotive engine oils
- Automotive Gear & Transmission oils
- Greases & Specialties

Industrial Lubricants

- Industrial oils
- Gear Oils • Hydraulic oils • Metal Working fluids
- Transformer oil • Industrial Greases
- Circulation oil, Thermic fluid, Turbine Oils



CORPORATE SOCIAL RESPONSIBILITY

Corporate Social Responsibility at **National Gas** is about doing our business in an ethical way, caring for our people, their families, the environment and the communities around us.



We benefit when our communities prosper, and our communities benefit when we prosper. Over the last three decades, we have invested in charitable, non-profit and community organisations. National Gas has supported programmes in education, health & safety, environment and arts & culture. We do whatever it takes to make our communities better places to live.





National Gas Company (S.A.O.G)

ONEIC Building, 2nd Floor, Alkhuwair, Tel: +968 22084900, Fax: +96822084901, info@nationalgasco.net, sales@nationalgasco.net

 NationalGasCo  NGCEnergy  National Gas Company SAOG

**National Gas Company S.A.O.G
Oman**

PO Box 95 , PC 124
Rusayl
Tel: +968 24446073
Fax: +968 24446307

**NGC Energy
UAE**

PO Box 3629
Umm Al Quwain
Tel: +971 67647607
Fax: +971 67647608

**NGC Energy LLC
KSA**

1202, Hail Center,
Al Raka, Al Khobar,
Tel: +966-13-8323313
Fax: +966-13-8331511

**NGC Energy Sdn. Bhd.
Malaysia**

Kuala Lumpur
Tel: +603 23328000
Fax: +603 23328001

www.nationalgasco.net